

S4D40120D 1200V SiC POWER SCHOTTKY RECTIFIER



Description

S4D40120D is a single SiC Schottky rectifier packaged in TO-247AD(TO-247-3) case. The device is a high voltage Schottky rectifier that has very low total conduction losses and very stable switching characteristics over temperature extremes. The S4D40120D is ideal for energy sensitive, high frequency applications in challenging environments.

Circuit Diagram

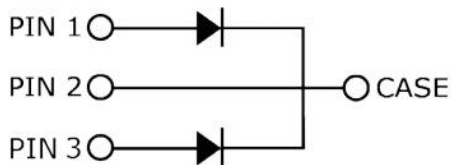

Features

- 175°C T_J operation
- Ultra-low switching loss
- Switching speeds independent of operating temperature
- Low total conduction losses
- High forward surge current capability
- High package isolation voltage
- Terminals finish: 100% Pure Tin
- “-A” is an AEC-Q101 qualified device
- Pb - Free Device
- All SMC parts are traceable to the wafer lot
- Additional electrical and life testing can be performed upon request

Applications

- Alternative energy inverters
- Power Factor Correction (PFC)
- Free-Wheeling diodes
- Switching supply output rectification
- Reverse polarity protection

Maximum Ratings:

Characteristics	Symbol	Condition	Max.	Units
Peak Repetitive Reverse Voltage Working Peak Reverse Voltage DC Blocking Voltage	V_{RRM} V_{RWM} V_R	-	1200	V
Average Rectified Forward Current (per leg)	$I_{F(AV)1}$	@Tc=25°C	59	A
	$I_{F(AV)2}$	@Tc=151°C	20	A
Repetitive Peak Forward Surge Current (per leg)	I_{FRM1}	10 ms, Half Sine pulse, Tc =25°C	86	A
	I_{FRM2}	10 ms, Half Sine pulse, Tc =110°C	56	A
Peak One Cycle Non-Repetitive Surge Current (per leg)	I_{FSM1}	10ms, Half Sine pulse, Tc =25°C	248	A
	I_{FSM2}	10ms, Half Sine pulse, Tc =110°C	205	A
Non-Repetitive Peak Forward Surge Current (per leg)	$I_{F,Max1}$	10µs. Pulse, Tc=25°C	1150	A
	$I_{F,Max2}$	10µs. Pulse, Tc =110°C	950	A
Power Dissipation (per leg)	P_{tot1}	Tc=25°C	263.2	W
	P_{tot2}	Tc=110°C	114.0	W

Electrical Characteristics:

Characteristics	Symbol	Condition	Typ.	Max.	Units
Forward Voltage Drop(per leg)*	V_{F1}	@ 20A, Pulse, T _J = 25 °C	1.5	1.8	V
	V_{F2}	@ 20A, Pulse, T _J = 175 °C	2.2	3.0	V
Reverse Current(per leg)*	I_{R1}	@V _R = rated V _R T _J = 25 °C	1	25	µA
	I_{R2}	@V _R = rated V _R T _J = 175 °C	10	150	µA
Junction Capacitance(per leg)	C_T	V _R =0V, T _J =25°C, f=1MHz	1620	-	pF
Reverse Recovery Charge(per leg)	Q_c	I _F = 20A, di/dt = 200A/µs V _R = 800 V, T _J =25°C	124.89	-	nC
Capacitance Stored Energy(per leg)	E_C	V _R = 800 V, T _J =25°C	64.20	-	µJ

* Pulse width < 300 µs, duty cycle < 2%

Thermal-Mechanical Specifications:

Characteristics	Symbol	Condition	Specification	Units
Junction Temperature	T _J	-	-55 to +175	°C
Storage Temperature	T _{stg}	-	-55 to +175	°C
Typical Thermal Resistance Junction to Case	R _{θJC}	DC operation, T _J =25°C	0.57(per leg) 0.29(both leg)	°C/W

Tube Specification

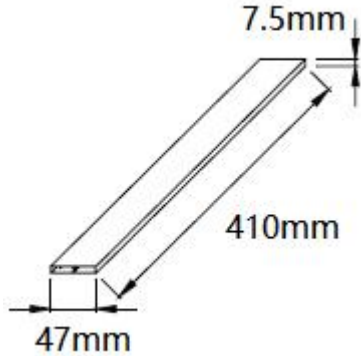

Marking Diagram

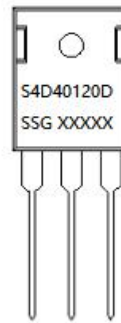

Where XXXXX is YYWWL

S4D = Device Type
D = Package type
40 = Forward Current (40A)
120 = Reverse Voltage (1200V)
SSG = SSG
YY = Year
WW = Week
L = Lot Number

Cautions: Molding resin
Epoxy resin UL:94V-0

Ordering Information

Device	Package	Shipping
S4D40120D	TO-247AD(TO-247-3)	25pcs /tube

Ratings and Characteristics Curves (per leg)

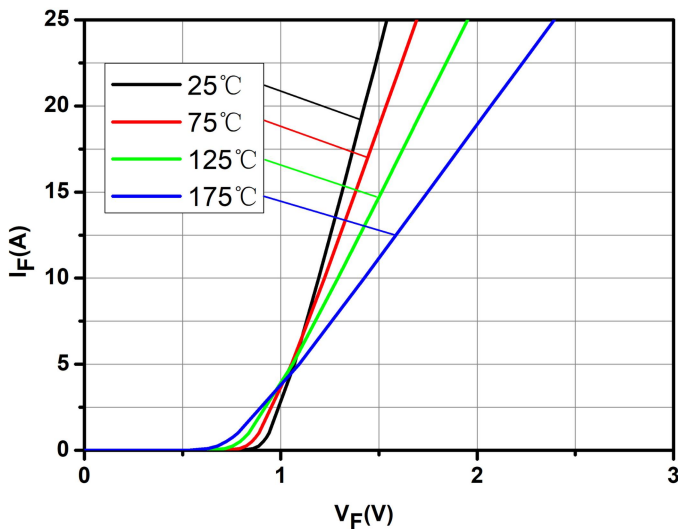

Fig.1-Typical Forward Voltage Characteristics

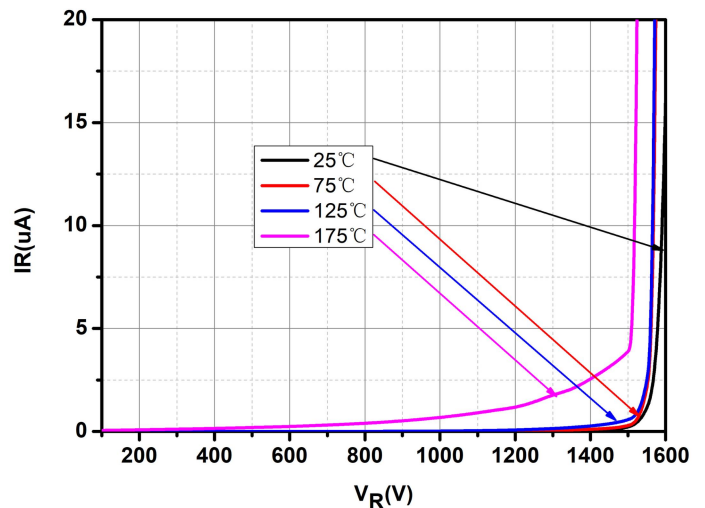

Fig.2-Typical Reverse Characteristics

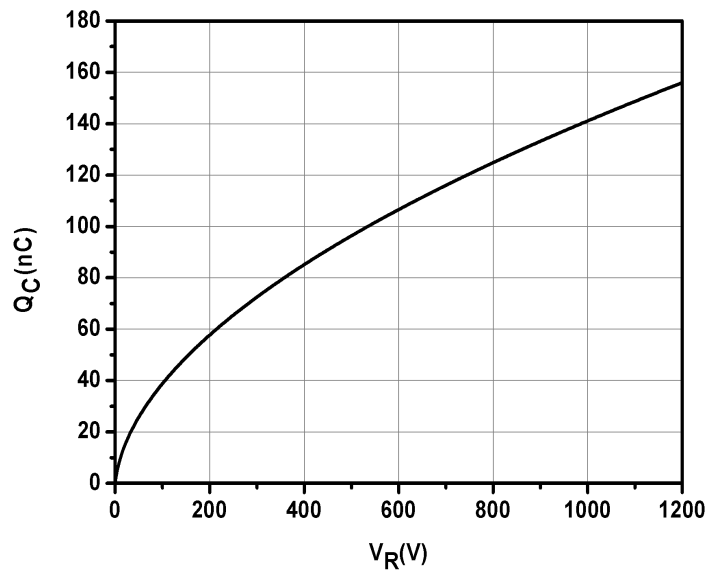
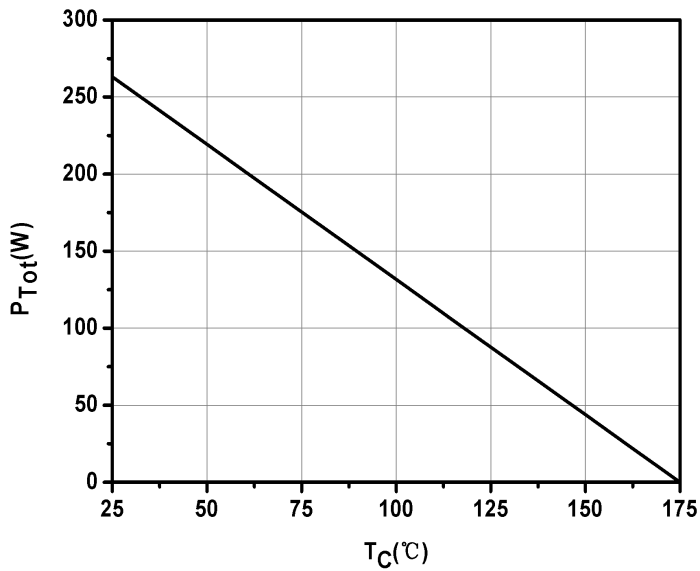
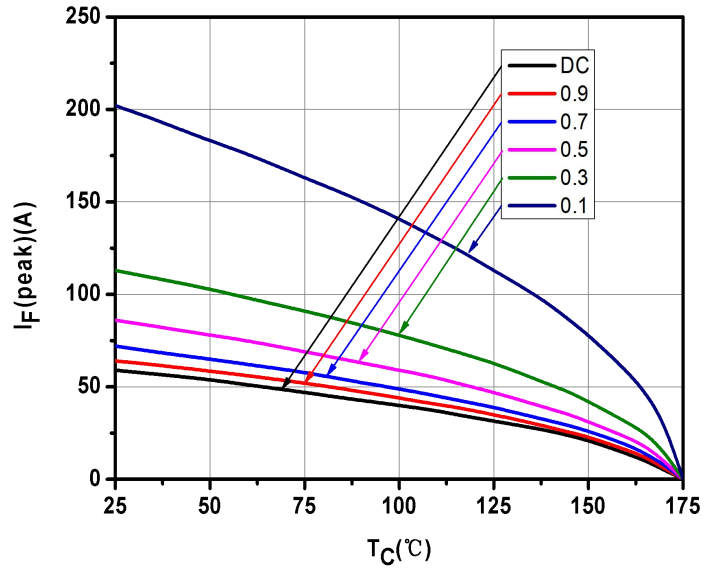
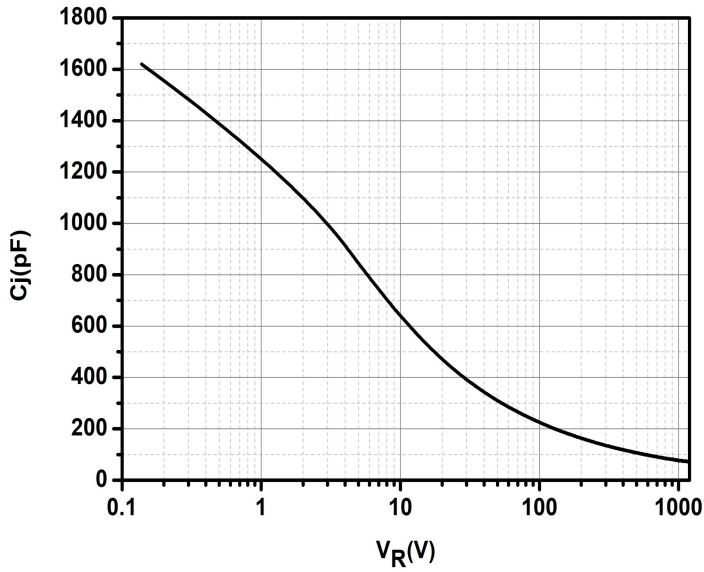

Fig.5-Power Derating

Fig.6-Total Capacitance Charge vs. Reverse Voltage

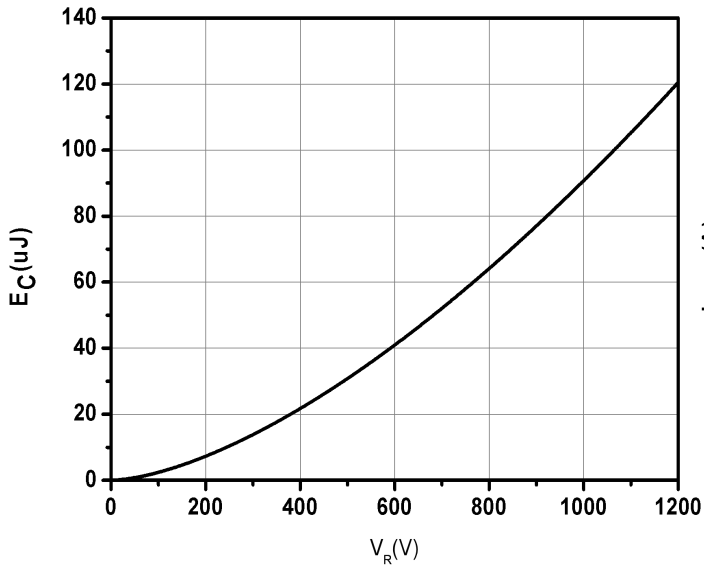

Fig.7-Capacitance Stored Energy

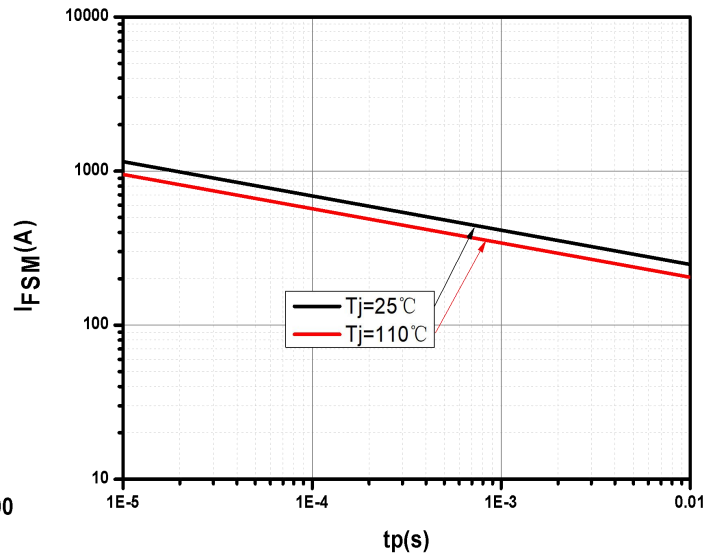
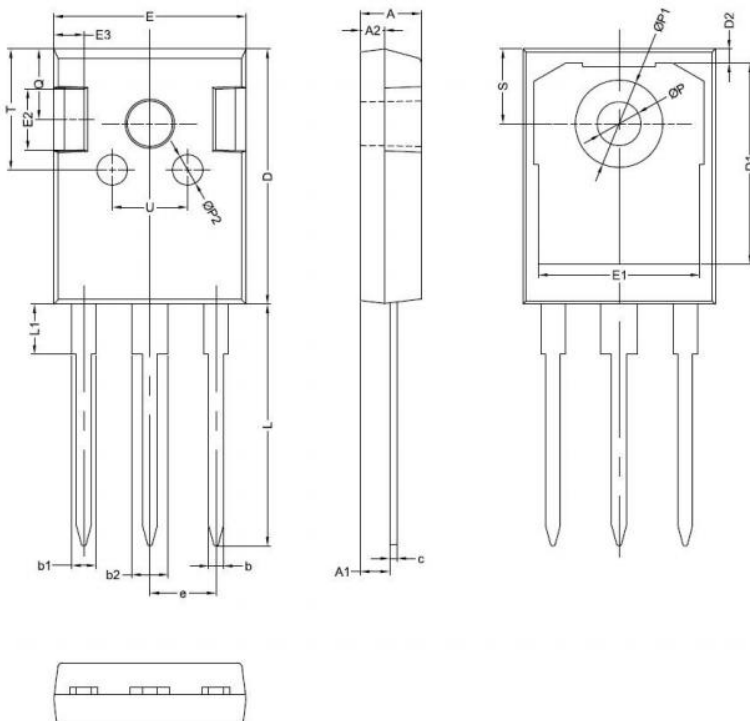

Fig.8-Non-repetitive peak forward surge current versus pulse duration (sinusoidal waveform)

Mechanical Dimensions TO-247AD



SYMBOL	Millimeters		
	MIN.	TYP.	MAX.
A	4.80	5.00	5.20
A1	2.20	2.41	2.61
A2	1.90	2.00	2.10
b	1.10	1.20	1.40
b1	1.80	2.00	2.20
b2	2.80	3.00	3.20
c	0.50	0.60	0.75
D	20.30	21.00	21.20
D1		16.55	
D2		1.20	
E	15.45	15.80	16.00
E1		13.30	
E2		5.00	
E3		2.50	
e		5.44	
L	19.42	19.92	20.70
L1		4.13	
P	3.50	3.60	3.70
P1	7.1		7.40
P2		2.50	
Q		5.80	
S	6.05	6.15	6.25
T		10.00	
U		6.20	

DISCLAIMER:

- 1- The information given herein, including the specifications and dimensions, is subject to change without prior notice to improve product characteristics. Before ordering, purchasers are advised to contact the SMC Diode Solutions sales department for the latest version of the datasheet(s).
- 2- In cases where extremely high reliability is required (such as use in nuclear power control, aerospace and aviation, traffic equipment, medical equipment, and safety equipment), safety should be ensured by using semiconductor devices that feature assured safety or by means of users' fail-safe precautions or other arrangement.
- 3- In no event shall SMC Diode Solutions be liable for any damages that may result from an accident or any other cause during operation of the user's units according to the datasheet(s). SMC Diode Solution assumes no responsibility for any intellectual property claims or any other problems that may result from applications of information, products or circuits described in the datasheets.
- 4- In no event shall SMC Diode Solutions be liable for any failure in a semiconductor device or any secondary damage resulting from use at a value exceeding the absolute maximum rating.
- 5- No license is granted by the datasheet(s) under any patents or other rights of any third party or SMC Diode Solutions.
- 6- The datasheet(s) may not be reproduced or duplicated, in any form, in whole or part, without the expressed written permission of SMC Diode Solutions.
- 7- The products (technologies) described in the datasheet(s) are not to be provided to any party whose purpose in their application will hinder maintenance of international peace and safety nor are they to be applied to that purpose by their direct purchasers or any third party. When exporting these products (technologies), the necessary procedures are to be taken in accordance with related laws and regulations..